



AGS-TECH Inc.

Phone: +1-505-550-6501 and +1-505-565-5102

Fax: +1-505-814-5778

Email: sales@agstech.net

Web: <http://www.agstech.net>



Welding Robot Expert

Create Brand,
Quality is the key to enhance the value,
Detail is the key of trusted!

Professional team engaged in research and development of robot application for 40 years
One of the Top Ten National First Batch of Robot Product Certification Enterprises



BRIEF INTRODUCTION

Factory was founded in 2007 with a registered capital of 121.6 million yuan invested by the Chinese famous university—Shanghai Jiao Tong University. Factory is a high-tech enterprise, focusing on welding robots, small 6 axis robots, collaborative robots for handling and high precision SCARA robots for pick and place applications. Factory core R & D team members are Phds and master graduates from Shanghai Jiao Tong University. CEO Mr Chen brought many design and controlling technologies to factory robots. factory is one of the frst group of industrial robot manufacturers in China.

Factory, as one of the leading Chinese robotic arm manufacturers, located near Shanghai, started with intelligent movement control boards since 2007 and focused on robotic controller research and development in 2011. In the same year, factory purchased an Italian robot factory. The Italian company has a long history as a robot manufacturer founded in 1978. It has developed a number of intelligent industrial robots, with a famous trademark. Factory assigned engineers to learn robot mechanical technology at Italian plant every year and put Italian mechanical style into the design of these robot bodies and electricity cabinets.

PRODUCT DIAGRAM

Welding Robot >>



MIG
MIG Welding Robot



TIG
TIG Welding Robot



Laser Welding Robot

Cutting Robot >>



Plasma Cutting Robot



Flame Cutting Robot



Laser Cutting Robot

Robot Auxiliary Equipment >>

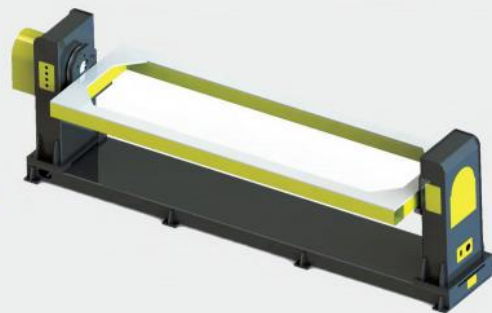

Uniaxial Positioner

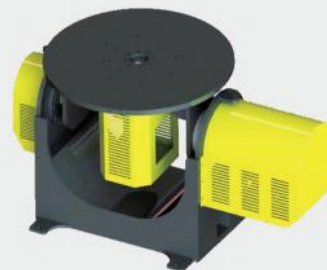

Biaxial Positioner

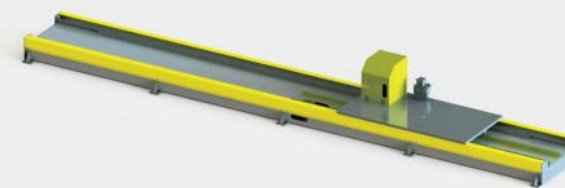

Walking Track of Robot



Carbon Steel

Stainless Steel



Aluminium Alloy

Special Metal

Machinable Material

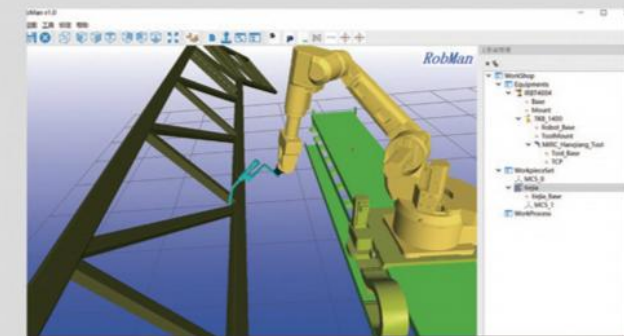

Off-line Programming

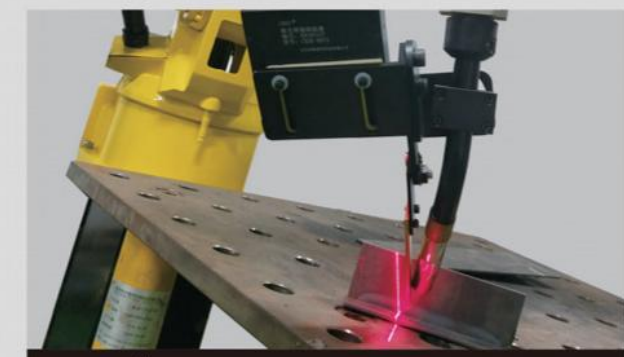

Laser Tracking

MIG

WELDING ROBOT SUIT



TKB-1440

TKB-2030

Application Diagram >>

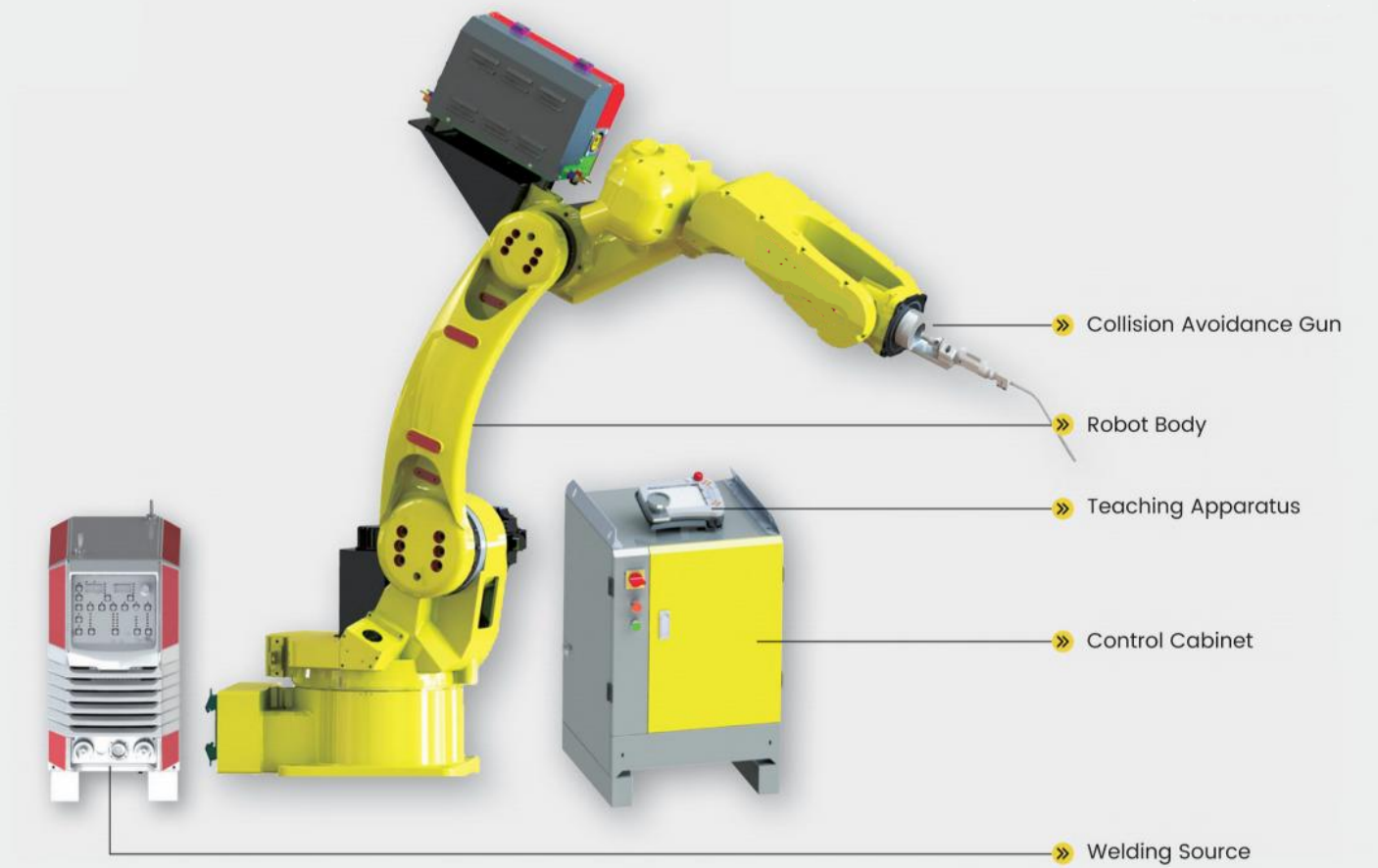

Technical Parameter >>

Model	TKB1440	
Payload	10kg	
Max Working Radius	1455mm	
DOF	6	
Body Weight	155kg	
Rated Power	4.3kw	
Max Speed	J1	198°/s
	J2	198°/s
	J3	169°/s
	J4	300°/s
	J5	240°/s
	J6	520°/s
Max Operation Area	J1	±170°
	J2	153°~-92°
	J3	75°~-100°
	J4	±190°
	J5	±130°
	J6	±360°
Protective specification	IP54	
Position Repeat Accuracy	±0.05mm	
Working Temperature	0~45℃	

PLASMA CUTTING ROBOT SUIT

TKB1400

TKB1600

TKB1900

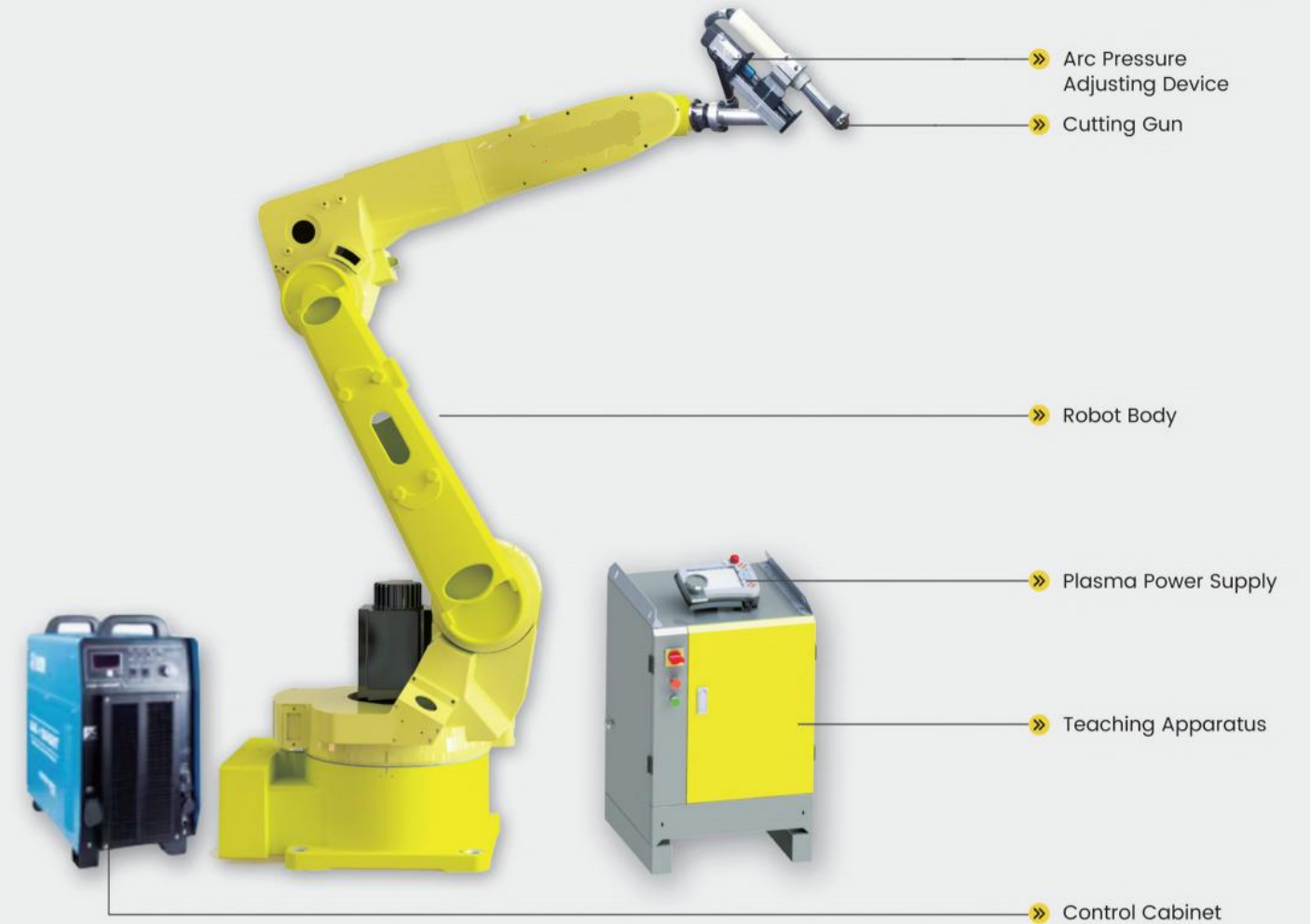

Application Diagram



Technical Parameter

Model	TKB1400	
Payload	6kg	
Max Working Radius	1412mm	
DOF	6	
Body Weight	160kg	
Rated Power	3.5kw	
Max Speed	J1	198°/s
	J2	198°/s
	J3	169°/s
	J4	360°/s
	J5	360°/s
	J6	600°/s
Max Operation Area	J1	± 170°
	J2	153°~92°
	J3	80°~100°
	J4	± 140°
	J5	± 120°
	J6	± 360°
Protective specification	IP54/IP67	
Position Repeat Accuracy	± 0.05mm	
Working Temperature	0~45°C	

TKB1600

Laser welding

Payload: 12kg
Arm Reach: 1410mm

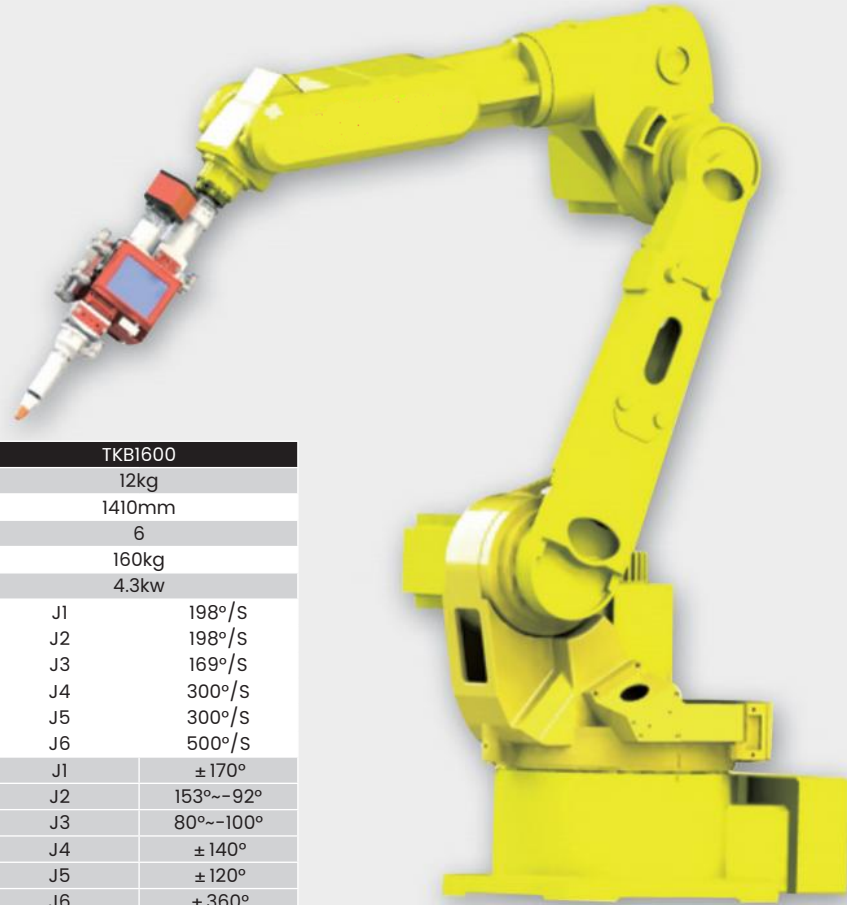

Technical Parameter >>

Model	TKB1600	
Payload	12kg	
Max Working Radius	1410mm	
DOF	6	
Body Weight	160kg	
Rated Power	4.3kw	
Max Speed	J1	198°/s
	J2	198°/s
	J3	169°/s
	J4	300°/s
	J5	300°/s
	J6	500°/s
Max Operation Area	J1	±170°
	J2	153°~92°
	J3	80°~100°
	J4	±140°
	J5	±120°
	J6	±360°
Protective specification	IP54/IP67	
Position Repeat Accuracy	±0.06mm	
Working Temperature	0~45℃	

TKB1400

Payload: 6kg
Arm Reach: 1412mm

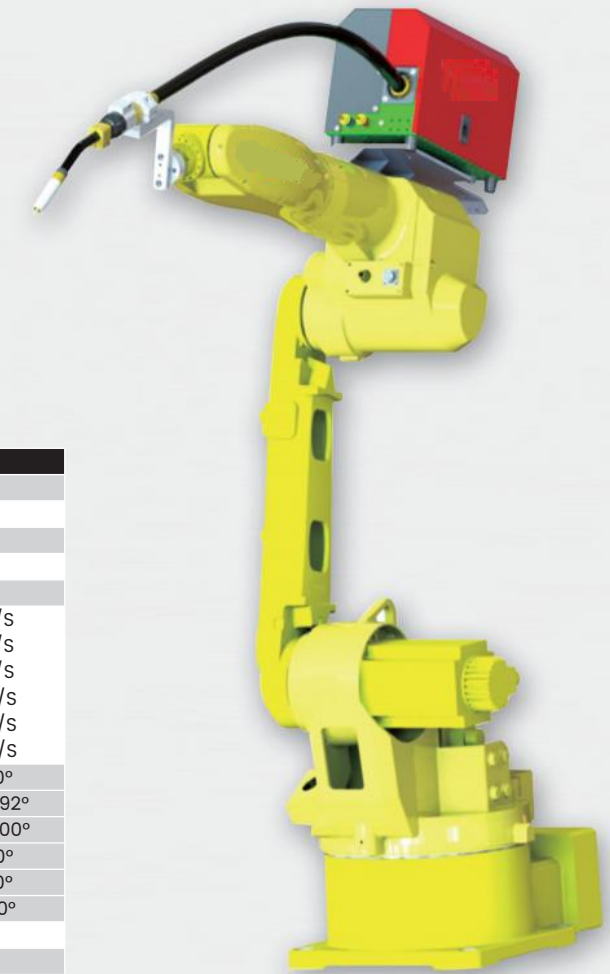

Technical Parameter >>

Model	TKB1400	
Payload	6kg	
Max Working Radius	1412mm	
DOF	6	
Body Weight	160kg	
Rated Power	3.5kw	
Max Speed	J1	198°/s
	J2	198°/s
	J3	169°/s
	J4	360°/s
	J5	360°/s
	J6	600°/s
Max Operation Area	J1	±170°
	J2	153°~92°
	J3	80°~100°
	J4	±140°
	J5	±120°
	J6	±360°
Protective specification	IP54/IP67	
Position Repeat Accuracy	±0.05mm	
Working Temperature	0~45℃	

Scope of work >>

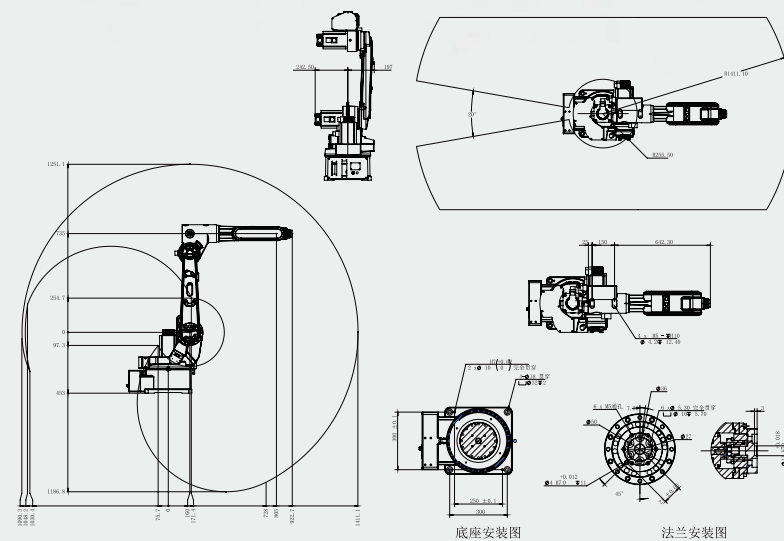

Scope of work >>

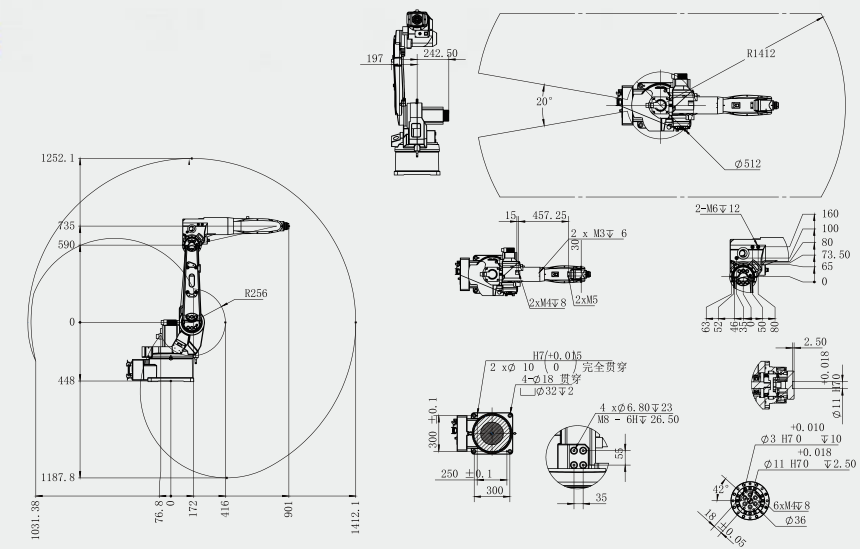

TKB-1900

Payload: 4kg
Arm Reach: 1940mm

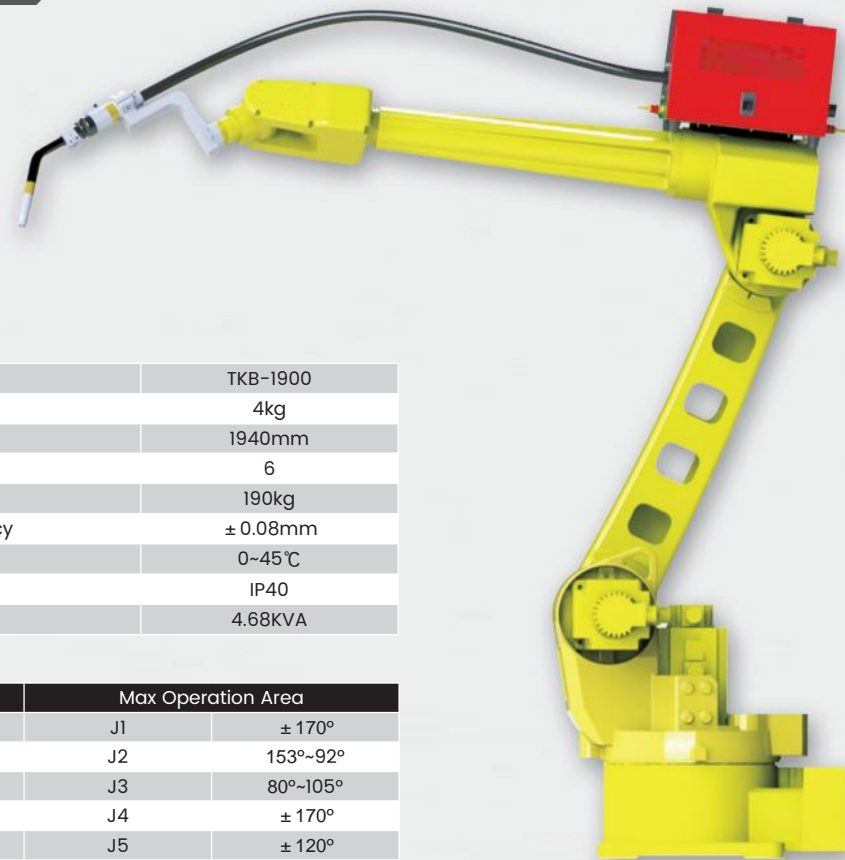

Technical Parameter

Model	TKB-1900
Payload	4kg
Max Working Radius	1940mm
DOF	6
Body Weight	190kg
Position Repeat Accuracy	± 0.08mm
Working Temperature	0~45°C
Protection Grade	IP40
Power Capacity	4.68KVA

Max Speed		Max Operation Area	
J1	140°/s	J1	± 170°
J2	150°/s	J2	153°~92°
J3	160°/s	J3	80°~105°
J4	245°/s	J4	± 170°
J5	300°/s	J5	± 120°
J6	450°/s	J6	± 360°

Scope of Work

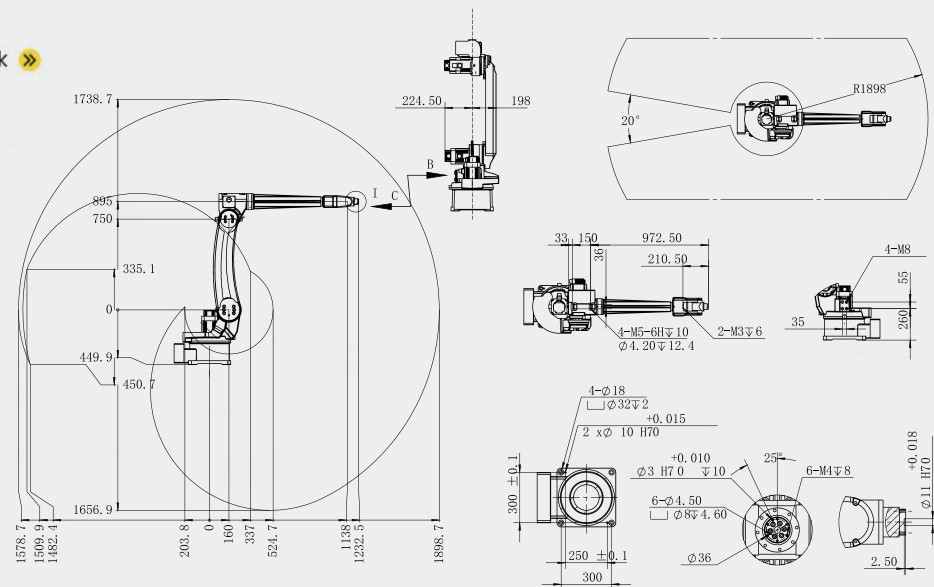

Technical Parameter



Model	J1			J2	J3	J4	
	STH30-400	STH30-500	STH30-600	250	150	-	
Axis Specification	Arm Length (mm)	150	250	350	250	150	-
	Rotation Range(°)	140 -140			140 -140	-	360 -360
Repeated Positioning Accuracy (XYZ:mm)(r:°)		± 0.01			± 0.01	± 0.02	± 0.016
Top speed (XYZ:mm/sec)(r:°/sec)		320			520	1020	600
Maximum Carrying Weight		3kg					
Standard Periodic Time (sec)		0.4					
R Axis Allowable Inertia Moment (kgm ²)		0.5					
(IN) (OUT)		0.2*10					
User Piping		φ4*3					
Length of Robot Cable (m)		Standard: 3 Optional: 5					
Host Weight (kg)		16.8-19kg					
Action Limit Setting		1					

Technical Parameter

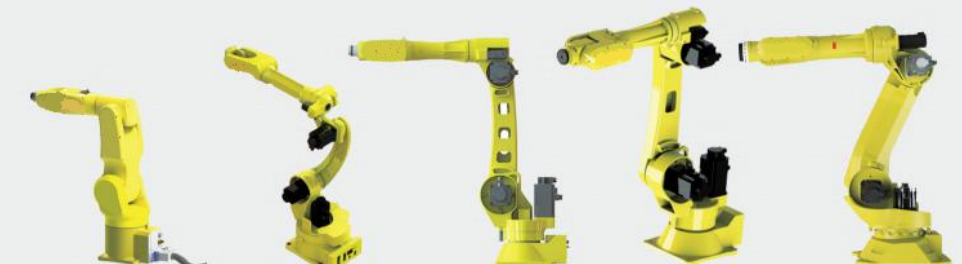

Model	TKB070	TKB2030	TKB2670	TKB3670	TKB6700
Payload	7kg	6kg	20kg	30kg	210kg
Max Working Radius	910mm	2078mm	1721mm	1721mm	2700mm
DOF	6	6	6	6	6
Body Weight	50kg	210kg	210kg	220kg	1131kg
Rated Power	2.4kw	4.3kw	4.5kw	5kw	8.5kw
Max Speed	J1 450°/s	J1 168°/s	J1 187°/s	J1 187°/s	J1 123°/s
	J2 360°/s	J2 148°/s	J2 148°/s	J2 148°/s	J2 115°/s
	J3 360°/s	J3 148°/s	J3 169°/s	J3 169°/s	J3 112°/s
	J4 450°/s	J4 300°/s	J4 234°/s	J4 234°/s	J4 179°/s
	J5 576°/s	J5 240°/s	J5 225°/s	J5 225°/s	J5 172°/s
	J6 720°/s	J6 520°/s	J6 360°/s	J6 225°/s	J6 219°/s
Max Operation Area	J1 ± 170°	J1 ± 160°	J1 ± 160°	J1 ± 160°	J1 ± 185°
	J2 110°~75°	J2 150°~90°	J2 150°~90°	J2 150°~90°	J2 85°~50°
	J3 50°~120°	J3 75°~100°	J3 80°~100°	J3 80°~100°	J3 120°~155°
	J4 ± 160°	J4 ± 190°	J4 ± 150°	J4 ± 150°	J4 ± 350°
	J5 ± 120°	J5 ± 130°	J5 ± 110°	J5 ± 110°	J5 ± 125°
	J6 ± 360°	J6 ± 360°	J6 ± 300°	J6 ± 300°	J6 ± 350°
Protective specification	J5J6 IP67 other IP54	IP54	IP54	IP54	J5J6 IP67 other IP54
Position Repeat Accuracy	± 0.02mm	± 0.07mm	± 0.05mm	± 0.05mm	± 0.7mm
Working Temperature	0~45°	0~45°	0~45°	0~45°	0~45°

TRC5-B06

INDUSTRIAL ROBOT CONTROL CABINET

The third generation of robot control cabinet, TRC3 control cabinet is a high-performance industrial robot control cabinet developed based on ETHRECAT bus by this factory introduced in Italy 40 years ago as industrial robot technology research and development experience, combined with domestic practical application experience. In addition to fully inheriting the advantages of the previous generation of products in motion control, flexibility, versatility, security, reliability and other aspects, TRC3 control cabinet also made new breakthroughs in distribution, modularization, user interface, bus communication, multi-robot coordination control, off-line simulation software and other aspects.



+ Arc welding package.....Cutting package
Positioner.....External shaft synergy Offline
Fill-in-the-blank programming.....programming

Technical Parameter »

Model	Configuration
processor	Intel J316
Memory capacity	4G DDR3
User storage space	MSATA solid state Drive 60GB
Demonstrator	8" TFT-LCD (resolution 1024*768), tempered touch screen, physical button, safety enable switch, emergency stop button, hand/automatic switch key.
Control cabinet switch buttons	Power switch, emergency stop button (optional hand/automatic switch, start button, stop button)
Control cabinet indicator light	Power indicator (optional running indicator and status indicator)
Number of control axes	The single machine has 6 axes, and can expand 3 external axes for linkage and cooperative movement. (Single axis rotation axis xy rotation axis, walking axis.
Number of I/O bits	Standard DI (digital input): 10 DO (digital output): 14 Optional DI (digital input): 18 DO (digital output): 10 Reserved for welding DI (digital input): 8 DO (digital output): 10 AO (analog output): 2
Supports external communication and interfaces	Ethernet interface RJ45 (TCP/IP, Modbus TCP); HDMI; USB
Security module	Associate emergency stop and ensure that the robot stops quickly when the robot is abnormal
Operation mode	Teaching, reproducing, remote
Programming methods	Teaching reproduction, off-line import, process programming
Process package	Welding process package, palletizing process package, dispensing process package, stamping process package, remote/appointment, visual follow process package
Motion function	Joint, straight line, arc, alignment machine linkage, coordination, conveyor belt to follow
Instruction system	Movement, logic, craft, arithmetic
Coordinate system	Joint coordinates, world coordinates, tool coordinates, user coordinates
Exception detection function	Emergency stop exception, servo exception, safety maintenance, arc starting exception, user coordinate exception, tool coordinate exception, etc
Application	Palletizing, loading and unloading, gas welding, argon arc welding, plasma cutting, spraying, gluing, polishing, stamping, visual follow grab
Protection level	IP65
Origin function	Absolute: battery memory; Zero calibration function
Cooling	Heat exchanger
Power supply	220V AC

FlexPendant »

Robot teaching device is a teaching terminal used in conjunction with robot control system. The teaching device uses a large size touch display, with high protection grade, ABS engineering plastic housing. Fully self-developed control system and programming method, providing online fill-in-the-blank programming teaching method. Enables beginners to grasp quickly.



Arc extinguishing parameter sticky wire detection

+ Optional off-line programming

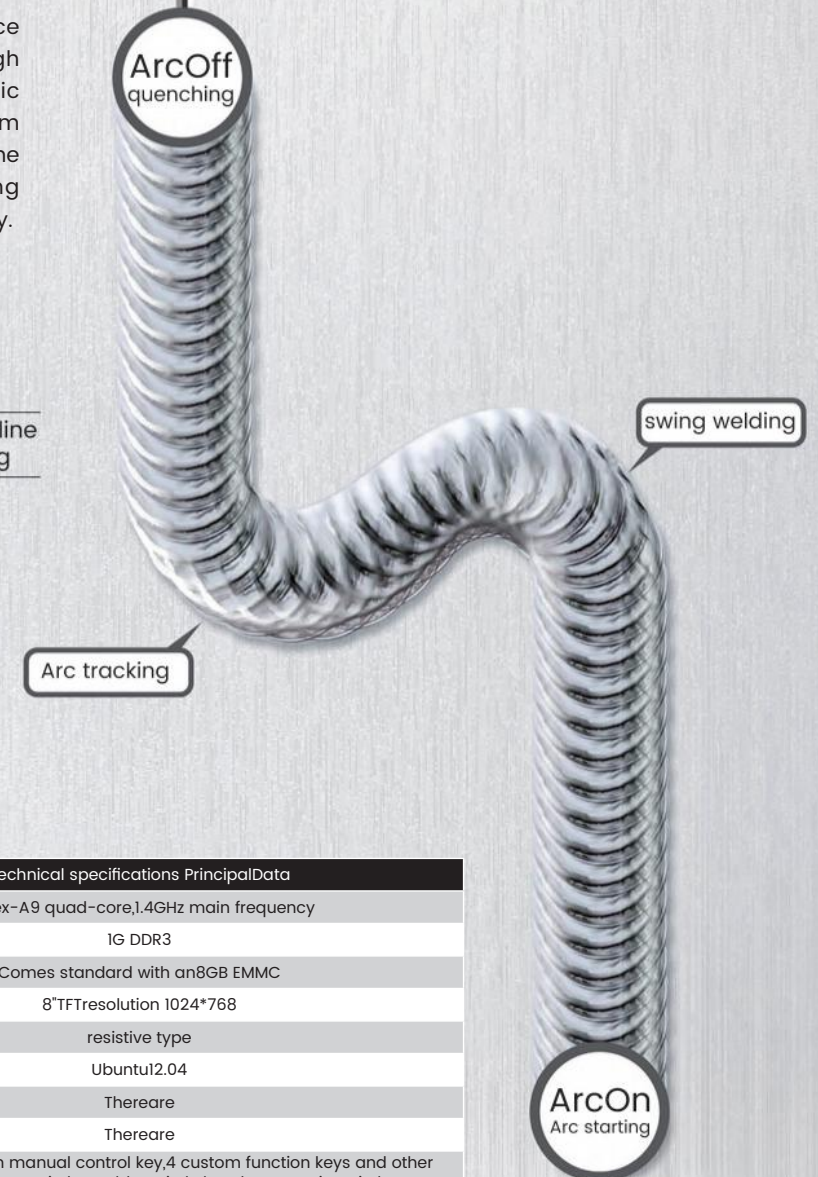

Technical Parameter »

Model	Technical specifications Principal Data
Processor	Cortex-A9 quad-core, 1.4GHz main frequency
Memory capacity	1G DDR3
Memory card	Comes standard with an 8GB EMMC
Touchscreen resolution	8" TFT resolution 1024*768
Touch screen	resistive type
Operating system	Ubuntu 12.04
Buzzer	There are
Internal integrated TF card slots	There are
Keys	Jog key 12, program manual control key, 4 custom function keys and other emergency stop switch, enable switch, hand automatic switch
Switches	key
Communication interface	Ethernet
norm	Protection class: IP54/65; Shell: ABS engineering plastic; Input voltage: 24VDC
Cable length	7m/10m
Power supply	DC24V about 20W
Overall dimensions	250*207*80mm

ArcOn
Arc starting

Arc initiation parameter swing parameter gas detection

LASER WELD TRACKER



The laser seam tracker has digitalized and integrated structure. It can detect and track many kinds of welds online and realize automation and intellectualization of welding



Technical Parameter

Laser Weld Tracker	
Dimensions	132*65*28mm
weight	390g
power	5W
Detection range	18mm*30mm
Mounting height	80mm
Detection accuracy	0.1mm/0.5mm/0.04mm
Welding type	MIG,MAG,TIG
Welding adaptability	Anti arc, anti splash, anti spot welding, anti electromagnetic interference
Weld form	Straight seam/ring seam/curved seam,etc; Splice/lap/fillet weld, etc

- Advantages of optical weld tracking
 - Non-contact and never wear
 - reducing heat load
 - increased productivity
 - Ensure safe welding and perfect welds
 - Can make the torch in the ideal position
 - Can compensate for production, equipment and operator
 - Consistent and reproducible connections can be achieved
 - For complex weldment can reduce programming work

OFF-LINE PROGRAMMING

- Robot off-line programming and simulation software
 - Automatic calculation and simulation of robot machining trajectory based on 3D geometric features
 - Support external axis collaboration tools
 - Applied to cutting, high-precision welding, intelligent flexible production

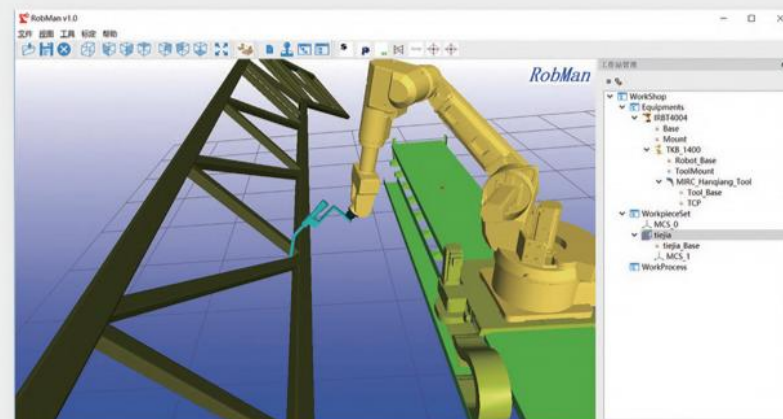

AUXILIARY EQUIPMENT



Walking Track of Robot

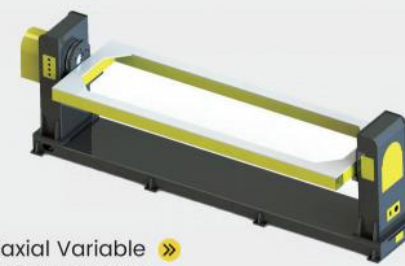

Uniaxial Variable Position Machine

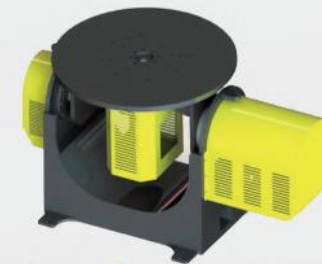

Biaxial Variable Position Machine

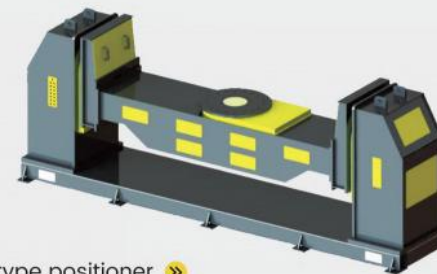

U-type positioner



L-type positioner

Model	TDG-500	TDG-1000
Maximum load	500kg	1000kg
Maximum velocity	800mm/s	400mm/s
Positioning accuracy	±0.1mm	±0.1mm
Stop position	Arbitrary	
Other	Itineraries can be customized	

Model	TBW-300	TBW-500	TBW-1000
Maximum load	200kg	500kg	1000kg
Maximum velocity	150°/s	120°/s	100°/s
Positioning accuracy	±0.1mm	±0.1mm	±0.1mm
Stop position	Arbitrary		
Other	Clamping frames are customizable		

Model	TBW-200 (s)	TBW-500 (s)	
Maximum load (2 axis center)	200kg	500kg	1 Axis range: ±90 2 Axis range: any Angle Note: Workpiece height ≤500mm
Maximum speed	1 axis 80°/s; 2 axis 100/s		
Positioning accuracy L=300mm light to I test heart line	±0.12mm	±0.12mm	

Model	Maximum load	Motor power	Maximum velocity	Positioning accuracy
TBW-300(U)	300	2.9 kW/1.6kW	67.7°/sec 45°/sec	0.08
TBW-600(U)	600	2.9 kW/1.8kW		0.12
TBW-1000(U)	1000	2.9 kW/2.9 kW		0.15

Model	Maximum load	Motor power	Maximum velocity	Positioning accuracy
TBW-500(L)	500	2.9kw 1.8kw	45°/sec 42°/sec	0.1
TBW-1000(L)	1000	2.9kw 1.8kw	42°/sec 10.8°/sec	0.15
TBW-2000(L)	2000	4.3kw 2.9kw	16.8°/sec 9.98°/sec	0.18

TRAINING



- Training Content**
- Robotic systems safety training
 - Robotic programming language advanced training
 - Fault handling and maintenance training
 - Robotics programming language beginner training
 - Training in instructional programming and operation of robots

- Training Mode**
- Standard curriculum
 - Customized training
 - Classroom instructions + hands on programming practice

APPLICATION CASE



SUPPORT

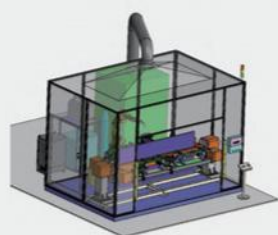

Holistic Robot Workstation

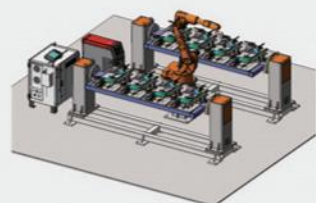

Eight Axis Double Station

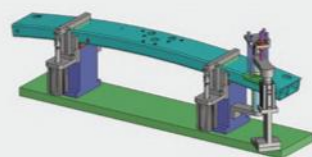

Work Fixture Scheme



Eight Axis Single Station



Robot + Walking Axis + Double Single Axis Transformer



Robot Side Hanging + Double Station



Welding Automation

Workpiece deformation due to exposure to heat and welding spatters adhering to the tooling and chuck in the welding process will affect uniformity of welding. Large workpiece and complicated weld joint also make teaching more cumbersome and require higher skills of commissioning and operating personnel. The new generation of welding technology of this plant pursues smart application adaptability and flexible weld path and by combining such technologies as laser tracker, 3D vision system and path generation, it makes the robots meet the various welding requirements with respect to resistance to external disturbance, adaptability to complex paths and commissioning in the welding process.

Welding with a these robots requires no human participation to realize automatic welding, thus reducing occurrence of occupational diseases and improving automation of the welding industry. With the special welding process package, the welding quality may be expressed with a value. Programmed welding operations facilitate high integration of application functions and easy commissioning. One automatic robot can finish the work of two to three welders, thus reducing the company's material and labor costs, enhancing yield, shortening the iteration cycle of the products and improving customer confidence and enterprise competitiveness.



Welding of New Energy Electric Bicycle Frame



3D Vision Guided Teach-free Welding

1. Electric car welding

TKB1440/TKB2030 welding robot with Aotai low spatter welder

- Combine with product characteristics, observe the deviation value of multiple batches of workpieces, and develop suitable process methods and program trajectory planning
- Simulate multiple welding sequences and



posture angles according to the product structure to achieve the shortest program trajectory time and improve the empty walking speed

- According to the characteristics of the product, develop differentiated parameters, from arc initiation to welding to arc closing precise control
- Flying arc saving arc initiation time, to the point of arc initiation, kinetic control of the movement program to achieve fast, accurate and stable

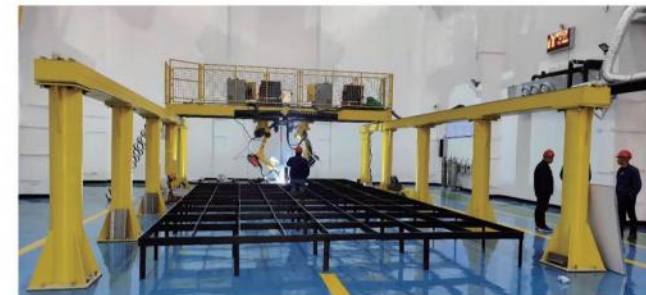

Ship Welding with Dual-robot Collaborative Laser Tracking

2. Robot upside down laser tracking welding ship structure with gantry system

- TKB1400 with pulse welding machine
- Adopting laser tracking process to solve the problem of large deviation
- Laser position finding is before welding, the laser first scans the product

to determine the weld position, and after the product position changes, the actual weld position is corrected for the path

- Laser real-time tracking is in welding, the laser real-time access to weld position, according to offset compensation, get the actual welding path
- Multi-functional pulse welder solves the need for welding multiple materials

Robot welding function introduction

- Full English interface, easy to operate
- Off-line simulation
- Precise control from arc initiation to welding process to arc closing
- Multi-layer and multi-pass
- Contact position finding
- Arc tracking
- Laser tracking
- 2D visual guidance
- 3D vision guidance

SOLUTIONS

Light Pole-Robot Welding / Cutting Station Solution

Two robots for welding and plasma cutting of light pole exported to Belarus were completed in collaboration.

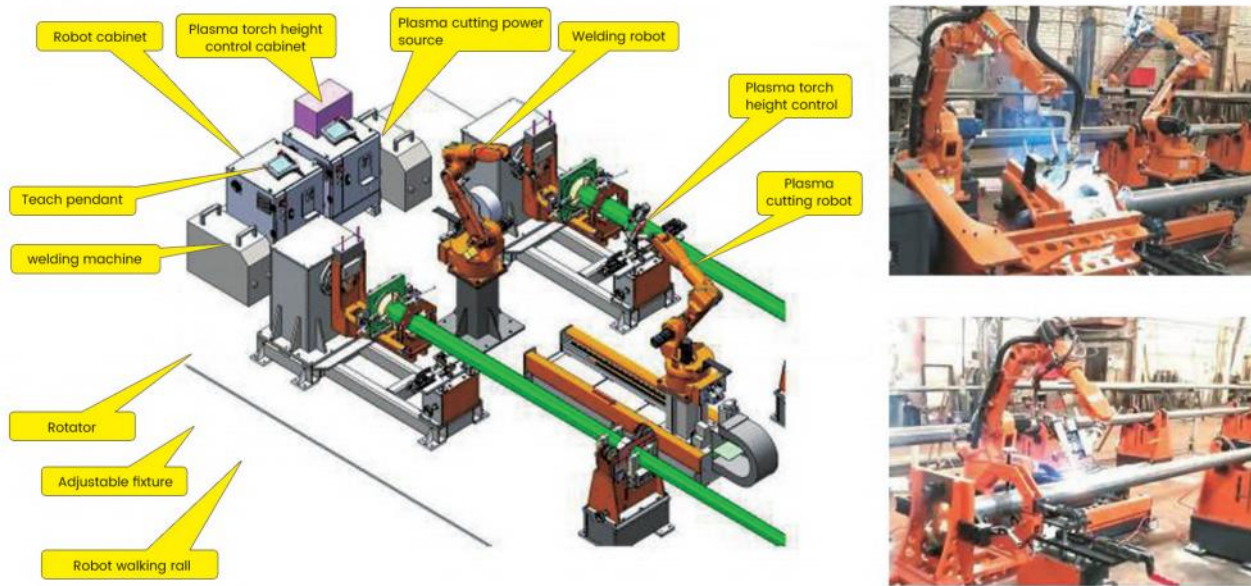

ARC Welding Robot With Laser Tracking

1. Laser tracking system scans the outline of welding part via feature points and collects the data
2. Controller uses its specific algorithm, data analysis and trajectory fitting
3. On the basis of fitting trajectory, teach program the actual position (only for the first time)
4. Before welding, the laser scans the featured points of the welding part to determine the position of the weld. If the part position changes, it calculates the deviation between the theoretical trajectory and the actual trajectory by the algorithm and corrects the path of the actual weld position.
5. Laser real-time tracking: In the welding the laser real-time obtains the position of the weld, compensates according to the offset, and obtains the actual welding path.



MAJOR CUSTOMERS

